

BEST AVAILABLE COPY

(12) INTERNATIONAL APPLICATION PUBLISHED UNDER THE PATENT COOPERATION TREATY (PCT)

(19) World Intellectual Property Organization
International Bureau



(43) International Publication Date
17 October 2002 (17.10.2002)

PCT

(10) International Publication Number
WO 02/081863 A1

- (51) International Patent Classification⁷: E21B 43/10, B21D 26/02
- (74) Agents: MCCALLUM, William, Potter et al.; Cruikshank & Fairweather, 19 Royal Exchange Square, Glasgow G1 3AF (GB).
- (21) International Application Number: PCT/GB01/04958
- (81) Designated States (*national*): AE, AG, AL, AM, AT, AU, AZ, BA, BB, BG, BR, BY, BZ, CA, CH, CN, CO, CR, CU, CZ, DE, DK, DM, DZ, EC, EE, ES, FI, GB, GD, GE, GH, GM, HR, HU, ID, IL, IN, IS, JP, KE, KG, KP, KR, KZ, LC, LK, LR, LS, LT, LU, LV, MA, MD, MG, MK, MN, MW, MX, MZ, NO, NZ, PH, PL, PT, RO, RU, SD, SE, SG, SI, SK, SL, TJ, TM, TR, TT, TZ, UA, UG, US, UZ, VN, YU, ZA, ZW.
- (22) International Filing Date: 8 November 2001 (08.11.2001)
- (25) Filing Language: English
- (26) Publication Language: English
- (30) Priority Data: 0108638.8 6 April 2001 (06.04.2001) GB
- (84) Designated States (*regional*): ARIPO patent (GI, GM, KE, LS, MW, MZ, SD, SI, SZ, TZ, UG, ZW), Eurasian patent (AM, AZ, BY, KG, KZ, MD, RU, TJ, TM), European patent (AT, BE, CH, CY, DE, DK, ES, FI, FR, GB, GR, IE, IT, LU, MC, NL, PT, SE, TR), OAPI patent (BF, BJ, CF, CG, CI, CM, GA, GN, GQ, GW, ML, MR, NE, SN, TD, TG).
- (71) Applicant (*for all designated States except US*): WEATHERFORD/LAMB, INC. [US/US]; c/o CSC - The United States Corporation Company, 1013 Centre Road, Wilmington, DE 19805 (US).
- (72) Inventors; and
- (75) Inventors/Applicants (*for US only*): SIMPSON, Neil, Andrew, Abercrombie [GB/GB]; Burn of Daff Farm, Downies, Portlethen, Aberdeen AB12 4QX (GB). HAU-GEN, David, Michael [US/US]; 408 North Iowa Ave, League City, TX 77573 (US).

Published:
— with international search report

For two-letter codes and other abbreviations, refer to the "Guidance Notes on Codes and Abbreviations" appearing at the beginning of each regular issue of the PCT Gazette.



WO 02/081863 A1

(54) Title: DOWNHOLE APPARATUS AND METHOD FOR EXPANDING A TUBING

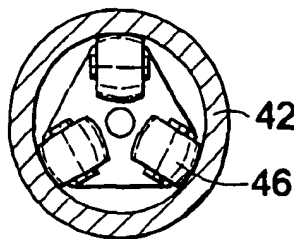

(57) Abstract: A method of expanding tubing comprises locating an expansion tool in a section of tubing to be expanded, applying a fluid pressure to the tubing to create a fluid pressure expansion force and induce a hoop stress in the tubing, and applying a mechanical expansion force to the tubing via the expansion tool. The combined fluid pressure expansion force and mechanical expansion force is selected to be sufficient to induce expansion of the tubing.

DOWNHOLE APPARATUS AND METHOD FOR EXPANDING A TUBING

FIELD OF THE INVENTION

This invention relates to tubing expansion, and in particular to expansion of tubing downhole.

BACKGROUND OF THE INVENTION

The oil and gas exploration and production industry is making increasing use of expandable tubing, primarily for use as casing and liner, and also in straddles, and as a support for expandable sand screens. Various forms of expansion tools have been utilised, including expansion dies, cones and mandrels which are pushed or pulled through tubing by mechanical or hydraulic forces. However, these tools require application of significant force to achieve expansion and must be packed with grease to serve as a lubricant between the faces of the cone and the tubing. A number of the difficulties associated with expansion cones and mandrels may be avoided by use of rotary expansion tools, which feature rolling elements for rolling contact with the tubing to be expanded while the tool is rotated and advanced through the tubing; a range of such tools is disclosed in WO00\37766, the disclosure of which is incorporated herein by reference. Although the expansion mechanism utilised in rotary expansion tools tends to require only relatively low actuation forces, the various

parts of the tools may experience high loading, for example the rollers may experience very high point loads where the roller surfaces contact the tubing under expansion. Clearly, such high loadings increase the rate of wear
5 experienced by the tools and the requirement to build the tools with the ability to withstand such loads tends to increase the cost and complexity of the tools.

GB 2348223 A, GB 2347950 A and GB 2344606 A (Shell Internationale Research Maatschappij B.V.) disclose various
10 arrangements in which a tubular member is extruded off a mandrel to expand the member. The axial force necessary to extrude and thus expand the member is achieved by creating an elevated fluid pressure chamber in the tubular member below the mandrel, which pressure creates an axial force on
15 the closed end of the tubular member below the mandrel sufficient to pull the member over the mandrel. The elevated fluid pressure acts only the expanded portion of the tubular member below the mandrel.

US Patent No. 5,083,608 (Abdrakhmanov et al) discloses
20 an arrangement for patching off troublesome zones in a well. The arrangement includes profile pipes which are run into a borehole and then subject to elevated internal pressure to straighten the pipes and bring them into engagement with the surrounding wall of the borehole. A
25 reamer is then rotated within the straightened pipes, with an axial load being applied to the reamer. The reamer is

utilised to expand the threaded joints of the pipe and to further straighten the pipe, and also to provide clearance between a seal on the reamer and the inner wall of the pipe which was utilised to permit the original fluid pressure
5 induced straightening of the pipe.

It is among the objectives of the present invention to provide an expansion method and apparatus which obviates or mitigates one or more disadvantages of the prior art expansion arrangements.

10 SUMMARY OF THE INVENTION

According to the present invention there is provided a method of plastically expanding a tubing, the method comprising:

15 applying a fluid pressure expansion force to a section of tubing; and

locating an expansion tool in the pressurised tubing and applying a mechanical expansion force to the pressurised tubing section, the combined fluid pressure force and mechanical expansion force being selected to be
20 sufficient to induce yield of the tubing.

The invention also relates to apparatus for providing such expansion.

The use of a combination of fluid pressure and mechanical forces allows expansion to be achieved using a
25 lower fluid pressure than would be necessary to achieve

expansion when relying solely on fluid pressure to induce expansion, and furthermore provides far greater control of the expansion process; it is generally difficult to predict the form of the expanded tubing that will result from a solely fluid pressure-induced expansion, and failure of tubing in such circumstances is common. Also, the combination of fluid pressure and mechanically-induced expansion allows expansion to be achieved while the loads experienced by the mechanical expansion tool remain relatively low, greatly extending the life of the tools. By way of example, a tubing may be subject to an internal fluid pressure selected to induce a hoop tensile stress which represents 60% of yield. By then applying an additional mechanically-applied expansion force sufficient to induce yield, the tubing may be expanded. Of course the relative proportions of the stress contributed by the fluid pressure and by the expander tool may be varied to suit particular applications, and issues to be taken into account may include: the nature of the tubing to be expanded, as lower quality tubing may respond in an unpredictable manner to elevated hydraulic pressures, such that a greater proportion of the stress must be mechanically applied, and thus greater control exercised over the expansion process; and the capabilities of the apparatus available, for example pump or fluid conduit capabilities may place limits on the applied fluid

pressures.

Various prior art proposals have utilised expansion dies or cones which are urged through tubing under the influence of an axial fluid pressure force acting on the die or cone, or in which tubing is extruded from a mandrel under the influence of axial fluid pressure force acting on the expanded tubing below the mandrel. However, in these instances the fluid pressure force is applied behind or below the die or cone, and the section of the tubing under expansion is not exposed to the elevated die-driving or tubing-extruding fluid pressure. Indeed, in order to provide the force necessary to drive the die or mandrel forward relative to the tubing in such existing arrangements, and to prevent leakage of the driving fluid past the die, it is necessary that there is an effective pressure-tight seal between the die and the expanded tubing. This seal may be provided by the contact between the die and the tubing wall, or by a separate seal assembly provided on the die.

It is a further advantage of the present invention that the fluid being utilised to pressurise the tubing may also serve as a lubricant between the expansion tool and the tubing, facilitating relative movement therebetween and thus reducing the degree of force necessary to move the expansion tool through the tubing. This is of particular significance where the expansion tool is a die or cone, and

the pressurising fluid provides an effectively infinite supply of lubricant, as opposed to the finite supply of grease or other lubricant provided in conventional expansion arrangements (see, for example, GB 2344606 A, in which a body of lubricant 275 is provided in the unexpanded portion of the tubing above the expansion mandrel); once the lubricant has been exhausted, the cone must be retrieved to the surface and repacked. Of course the presence of a lubricant will also reduce the rate of wear to the bearing portions of the expansion tool.

Although intended primarily for use in expanding bore-lining metal tubing, the invention has application in other downhole applications, and may also be used in subsea or surface applications.

The expansion tool may take any appropriate form, including an expansion die or cone, and may be in the form of a cone or other member carrying a plurality of rollers rotatable about axes substantially perpendicular to the tubing axis. However, it is preferred that the expansion tool is a rotary expansion tool, or rolling element expander, that is the tool features at least one expansion member which, in use, is in rolling contact with the tubing wall; the expansion member may follow a circumferential or helical contact path with the tubing wall. Most preferably, the expansion members are conical in form or are mounted on axes arranged to define a cone. In another

embodiment of the invention, a rotating expansion tool may be utilised which features a non-rotating expansion member or members, preferably of a relatively hard material such as a ceramic material, which provides a sliding contact
5 with the tubing wall. The members may be radially extendable or may be radially fixed. In one embodiment, blocks of silicon carbide or titanium carbide may form the expansion members.

Preferably, the expansion tool is fluid pressure
10 actuated, and may include a hydraulic drive motor to rotate the tool; the motor may utilise the fluid providing the expansion force as a drive fluid, the fluid exhausting into a lower pressure section of the bore isolated from the expansion section. In other embodiments, an electric motor
15 may be utilised.

The expansion tool is preferably provided in combination with a seal assembly, for providing a fluid-tight seal with the unexpanded tubing ahead of the expansion tool. As the fluid pressure in the unexpanded
20 tubing ahead of the seal assembly will tend to be lower than the elevated pressure behind the seal assembly, this differential pressure will tend to produce an axial pressure force acting on the seal assembly, which may be utilised to drive the expansion tool forwards.

BRIEF DESCRIPTION OF THE DRAWINGS

These and other aspects of the present invention will now be described, by way of example, with reference to the accompanying drawings, in which:

5 Figure 1 is a schematic sectional view of tubing expansion apparatus in accordance with a preferred embodiment of the present invention;

 Figure 2 is a diagrammatic part-sectional view of an expansion tool of expansion apparatus in accordance with
10 another embodiment of the present invention;

 Figures 3, 4, 5 and 6 are sectional views on lines 3 - 3, 4 - 4, 5 - 5 and 6 - 6 of Figure 2; and

 Figure 7 is a diagrammatic part-sectional view of an expansion apparatus in accordance with a further embodiment
15 of the present invention.

DETAILED DESCRIPTION OF THE DRAWINGS

Reference is first made to Figure 1 of the drawings, which illustrates expansion apparatus 10 in accordance with a preferred embodiment of the present invention, shown
20 located in the upper end of a section of tubing in the form of bore liner of expandable metal, hereinafter referred to as liner 12. In use, the apparatus 10 and liner 12 are run into a drilled bore together, and the liner 12 positioned in a section of unlined bore, and possibly overlapping the
25 lower end of existing bore-lining casing. The apparatus 10

is then operated to expand the liner 12 to a larger diameter, the liner of the original, unexpanded diameter being identified as liner 12a, and the expanded larger diameter liner being identified by the reference numeral
5 12b.

The apparatus 10 includes a rolling element expander 14 having a generally conical body 16 carrying a number of rolling elements 18. The expander 14 is coupled to a hydraulic drive motor 20 mounted on a running tube 22 which
10 extends upwardly, through a stuffing box 24, to surface. The stuffing box 24 is provided in an upper seal assembly 26 mounted to the top of the liner 12. Mounted below the expander 14, via a swivel 28, is a lower seal assembly 30 which is adapted to provide a sliding seal with the
15 unexpanded liner 12a.

In use, the volume 32 defined by the liner 12 between the seal assemblies 26, 30 is supplied with high pressure hydraulic fluid from an appropriate source, such as a surface or downhole pump. In Figure 1 a hydraulic fluid
20 inlet 34 is illustrated as passing radially through a part of the upper seal assembly 26, however in practice the inlet 34 would be arranged axially, to allow accommodation of the apparatus 10 in a bore, and to allow supply of hydraulic fluid via a running tube in the form of a coaxial
25 coil tubing or drill pipe. The pressure of the hydraulic fluid is selected to induce a predetermined hoop tensile

stress within the liner 12. The hydraulic fluid exhausts through the drive motor 20, which includes a hydraulic fluid driven turbine, the exhausted fluid passing up to the surface via the running tube 22.

5 The exhausted fluid is throttled, or the flow and pressure of the fluid otherwise controlled, to control the pressure within the volume 32, and also the operation of the motor. The throttling may take place downhole or at surface.

10 The passage of fluid through the motor 20 causes the motor to rotate the expander 14, and thus if the motor 20 is advanced through the liner 12, the expander 14 will act on the transition portion 12c between the section of unexpanded and expanded liner 12a, 12b. The forces acting
15 on the transition portion 12c comprise a combination of the stress induced by the elevated hydraulic fluid pressure within the volume 32, and the mechanical pressure forces applied by the surfaces of the rolling elements 18. The combination of forces is selected so as to be sufficient to
20 induce yield and thus plastic deformation of the liner 12.

 As noted above, the lower seal assembly 30 isolates the pressurised volume 32 from the remainder of the unexpanded liner 12a, which is at a lower pressure than the volume 32. Accordingly, the differential pressure acting
25 on the assembly 30 produces an axial force tending to push the apparatus 10 through the liner 12. There is thus no

requirement to apply weight from surface to the apparatus
10.

EXAMPLE

5 A liner 12 to be expanded is 7 $\frac{5}{8}$ " 29.7 lb\ft N80 tubing
which has a burst pressure of approximately 7,000 psi. The
hydraulic fluid supplied to the volume 32 is at 5,000 psi.
The liner wall is therefore subjected to a tensile stress
of 51,000 psi, which represents 63% of the yield for the
10 liner (not taking into account the effect of radial stress
in the region of 25,000 psi).

 The drive fluid to the hydraulic motor 20 enters
through an inlet port 36 and exhausts into the running tube
22, thereby adding the motor pressure drop to the applied
15 internal pressure. The hydraulic return to surface is
throttled to maintain the applied liner pressure, taking
into account the motor pressure drop and the parasitic
losses in the running tube 22.

 The net axial force applied to the expansion assembly
20 is the pressure differential across the lower seal assembly
30 times its cross-sectional area minus the pressure
differential across the stuffing box 24 times the cross-
sectional area of the running tube 22. If the running tube
22 has an outside diameter of 5" and the internal diameter
25 of the 7 $\frac{5}{8}$ " liner is 6.88", then the down force applied to
the assembly is 83,000 lbf, which is in excess of the force

required to drive the expander 14 through the liner 12, such that a braking assembly must be provided on surface for the running tube 22. Alternatively, a larger diameter running tube 22 could be utilised.

5 Reference is now made to Figures 2 to 6 of the drawings, which illustrate an alternative expander 40 in accordance with a further embodiment of the present invention, shown located in a section of liner 42 during expansion. From a comparison of the figures, those of
10 skill in the art will recognise that Figure 2 shows various internal features of the expander 40.

The expander 40 features a generally conical body 44 on which are mounted five rows of rollers 46, 47, 48, 49 and 50 (the section shown in Figure 6 corresponds to both
15 sections 6-6 and 6a-6a of Figure 2). Unlike the rolling elements 18 of the first described embodiment, the rollers 46 to 50 rotate around axes that lie substantially perpendicular to the liner axis, and the expander 40 is therefore intended to advance axially through the liner 42,
20 without rotation.

Such an expander configuration would not be practical in the absence of assisting hydraulic expansion forces, as the bearing loads experienced on expanding heavy walled tubing would far exceed the capabilities of the bearings
25 that could be installed in the limited space available. However, with applied internal hydraulic pressure providing

the bulk of the expansion forces, the roller bearings are relatively lightly loaded.

Reference is now made to Figure 7 of the drawings, which illustrates an expansion apparatus 60 in accordance with a further embodiment of the present invention located
5 within a partially expanded borehole liner 58.

The apparatus 60 includes an expander cone 62 mounted to a tubular running string 64, and mounted below the cone 62 is a seal assembly 66 adapted to provide a sliding seal
10 with the unexpanded liner 58.

As with the above described embodiments, an elevated fluid pressure above the seal assembly 66 provides an initial expansion force acting on the liner 58, while the passage of the cone 62 provides a further mechanical
15 expansion force which, in combination with the hydraulic expansion force, is sufficient to induce yield in the liner 58. The axial pressure force acting on the seal assembly 56 may also serve to drive the cone 60 through the tubing 58, and the presence of the pressurising force around the
20 cone 62 provides an effectively infinite supply of lubricant for the cone 62; fluid communication across the cone 62 may be assured by providing linked ports 68, 70 above and below the cone 62.

It will be apparent to those of skill in the art that
25 the above-described embodiments provide an alternative method for expanding tubing downhole, and that the

invention offers a number of advantages over existing systems.

Furthermore, those of skilled in the art will recognise that the above-described embodiments are merely
5 exemplary of the present invention, and that various modifications and improvements may be made thereto, without departing from the scope of the invention. For example, in the embodiment of Figure 1, rather than providing a hydraulic fluid driven motor 20 within the pressurised
10 volume 32, a motor may be provided externally of the volume 32, and may be located downhole or at surface. In this case, the upper seal assembly 26 would of course have to be modified to accommodate rotation.

CLAIMS

1. A method of expanding tubing, the method comprising:
locating an expansion tool in a section of tubing to
be expanded;
5 applying fluid pressure to said section of tubing to
create a fluid pressure expansion force and induce a hoop
stress in said section of tubing; and
applying a mechanical expansion force to said tubing
section via said expansion tool, the combined fluid
10 pressure expansion force and mechanical expansion force
being selected to be sufficient to induce expansion of the
tubing.
2. The method of claim 1, further comprising locating the
tubing downhole.
- 15 3. The method of claim 1 or 2, comprising inducing
plastic deformation of the tubing.
4. The method of claim 1, 2 or 3, comprising selecting
the fluid pressure to create a hoop stress in said tubing
section representing at least 25% of the yield stress of
20 the tubing.

5. The method of claim 4, comprising selecting the fluid pressure to create a hoop stress in said tubing section representing at least 40% of the yield stress of the tubing.
- 5 6. The method of claim 5, comprising selecting the fluid pressure to create a hoop stress in said tubing section representing at least 50% of the yield stress of the tubing.
- 10 7. The method of claim 6, comprising selecting the fluid pressure to create a hoop stress in said tubing section representing at least 60% of the yield stress of the tubing.
- 15 8. The method of any of the preceding claims, further comprising utilising fluid utilised to create the fluid pressure expansion force as a lubricant between the expansion tool and the tubing.
9. The method of any of the preceding claims, comprising providing the expansion tool is the form of an expansion die and running the die axially through the tubing section.
- 20 10. The method of any of claims 1 to 8, comprising providing the expansion tool in the form of an expansion

member carrying a plurality of rolling expansion members rotatable about axes which are substantially perpendicular to the tubing axis, and running the expansion member axially through the tubing section.

- 5 11. The method of any of claims 1 to 8, comprising providing the expansion tool in the form of a rolling element expander having at least one expansion member in rolling contact with the tubing wall, and rotating the expander in the tubing section.
- 10 12. The method of any of the preceding claims, comprising utilising fluid to actuate the expansion tool.
- 15 13. The method of claim 12, comprising providing a hydraulic drive motor to rotate the expansion tool, the motor utilising fluid providing the fluid pressure expansion force as a drive fluid.
14. The method of any of the preceding claims, comprising providing the expansion tool in combination with a seal assembly providing a fluid-tight seal with the unexpanded tubing ahead of the expansion tool.
- 20 15. The method of claim 14, comprising applying said fluid pressure to the seal assembly to drive the expansion tool

axially relative to the tubing.

16. A method of expanding a tubular, comprising:

(a) applying fluid pressure to an inside surface of the tubular;

5 (b) applying a mechanical force to the inside surface of the tubular; and

(c) expanding the tubular with the combination of the fluid pressure and the mechanical force.

17. A method of increasing an outer diameter and inner diameter of a tubular, comprising:

(a) applying fluid pressure to an inside surface of the tubular;

(b) applying a mechanical force to the inside surface of the tubular; and

15 (c) increasing the outer diameter and the inner diameter of the tubular with the combination of the fluid pressure and the mechanical force.

18. A method of increasing an outer diameter and inner diameter of a tubular, comprising:

20 (a) applying fluid pressure to an inside surface of the tubular;

(b) applying a mechanical force to the inside surface of the tubular at least partially simultaneously with the

application of fluid pressure; and

(c) increasing the outer diameter and the inner diameter of the tubular with the combination of the fluid pressure and the mechanical force.

- 5 19. The method of claim 16, 17 or 18, wherein the tubular is a downhole tubular.
20. The method of claim 16, 17, 18 or 19, wherein the fluid pressure causes the tubular wall to approach its yield strength.
- 10 21. The method of any of claims 16 to 20, wherein the mechanical force urges the tubular to expand.
22. The method of any of claims 16 to 21, wherein the expansion is plastic.
23. A method of plastically expanding a downhole tubular,
15 comprising applying a combination of hydraulic and mechanical expansion forces to unexpanded and expanding portions of the tubular wall, the applied hydraulic expansion force being selected to provide sufficient stress in the tubular wall to cause the wall to approach but not
20 exceed its yield strength, and the mechanically applied force providing an additional stress required to push the

tubular wall through yield and causing controlled local expansion of the tubular wall.

24. Apparatus for expanding a tubing, the apparatus comprising:

5 means for isolating the interior of a section of tubing;

 means for supplying fluid at elevated pressure to the isolated section of tubing to create a fluid pressure expansion force on the tubing wall; and

10 an expansion tool for location in the pressurised section of tubing and adapted to apply a mechanical expansion force to the tubing wall simultaneously with the fluid pressure expansion force.

25. The apparatus of claim 24, wherein the expansion tool
15 is an expansion die adapted to be moved axially through the tubing section.

26. The apparatus of claim 24, wherein the expansion tool has a body carrying a plurality of expansion members rotatable about axes substantially perpendicular to the
20 tubing axis and is adapted to be moved axially through the tubing section.

27. The apparatus of claim 24, wherein the expansion tool

has at least one expansion member and is adapted to be rotated in the tubing section.

28. The apparatus of claim 27, wherein the expansion member is radially movable.

5 29. The apparatus of claim 27 or 28, wherein the expansion tool is a rolling element expander having a plurality of rotatable expansion members.

30. The apparatus of claim 29, wherein the expansion members are arranged to define a cone.

10 31. The apparatus of any of claims 24 to 30, wherein the expansion tool is fluid pressure actuated.

32. The apparatus of claim 31, wherein the expansion tool includes a hydraulic drive motor to rotate parts of the tool.

15 33. The apparatus of any of claims 24 to 32, wherein said isolating means includes a seal assembly for providing a fluid-tight seal with unexpanded tubing ahead of the expansion tool.

34. The apparatus of claim 33, wherein a swivel is

provided between the expansion tool and the seal assembly.

35. The apparatus of any of claims 23 to 34, wherein said means for supplying fluid at elevated pressure includes a first conduit for carrying fluid to the interior of the section of tubing and a second conduit for carrying fluid from said section of tubing.

36. The apparatus of any of claims 24 to 35, wherein said means for supplying fluid at elevated pressure includes a coaxial support member.

37. The apparatus of any of claims 24 to 36, wherein said means for supplying fluid at elevated pressure includes a throttle for controlling the pressure of fluid in said section of tubing.

38. The apparatus of any of claims 24 to 37, in combination with a section of expandable tubing.

39. The combination of claim 38, wherein the tubing is bore-lining tubing.

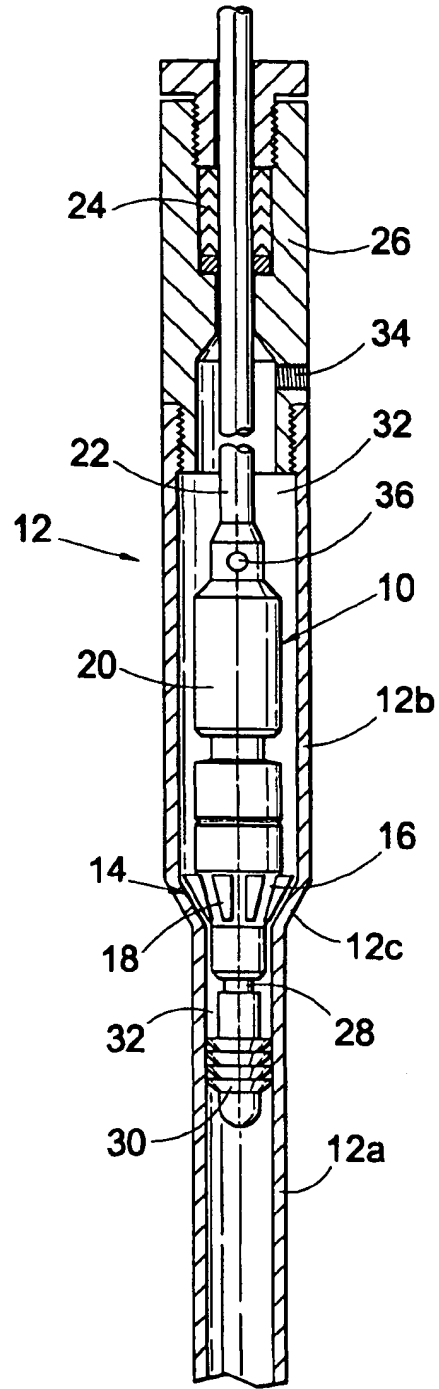

Fig.1

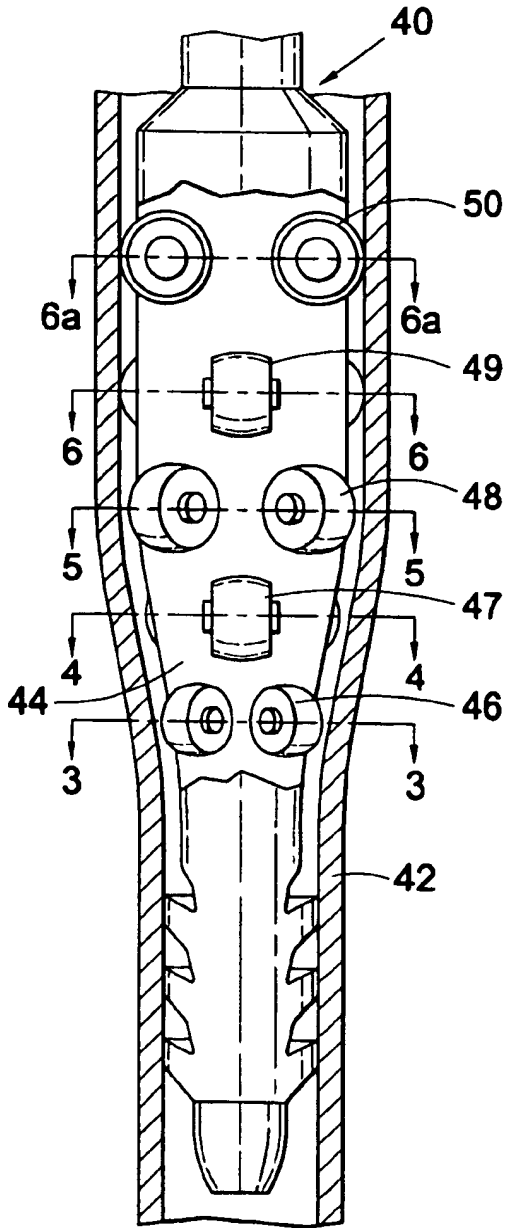

Fig.2

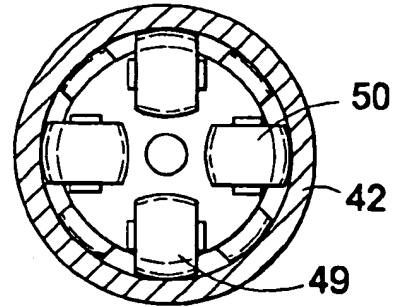

Fig.6

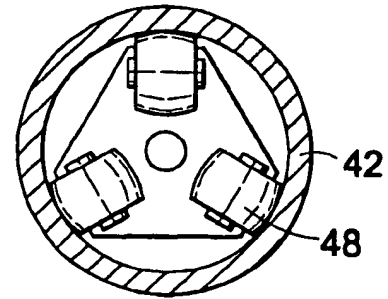

Fig.5

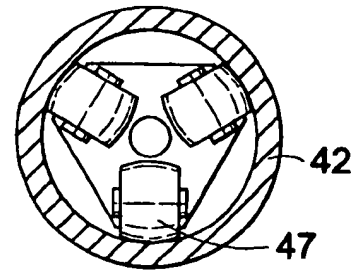

Fig.4

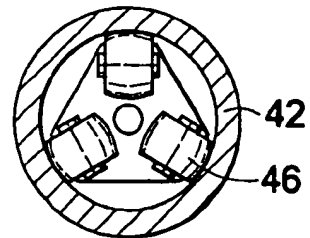
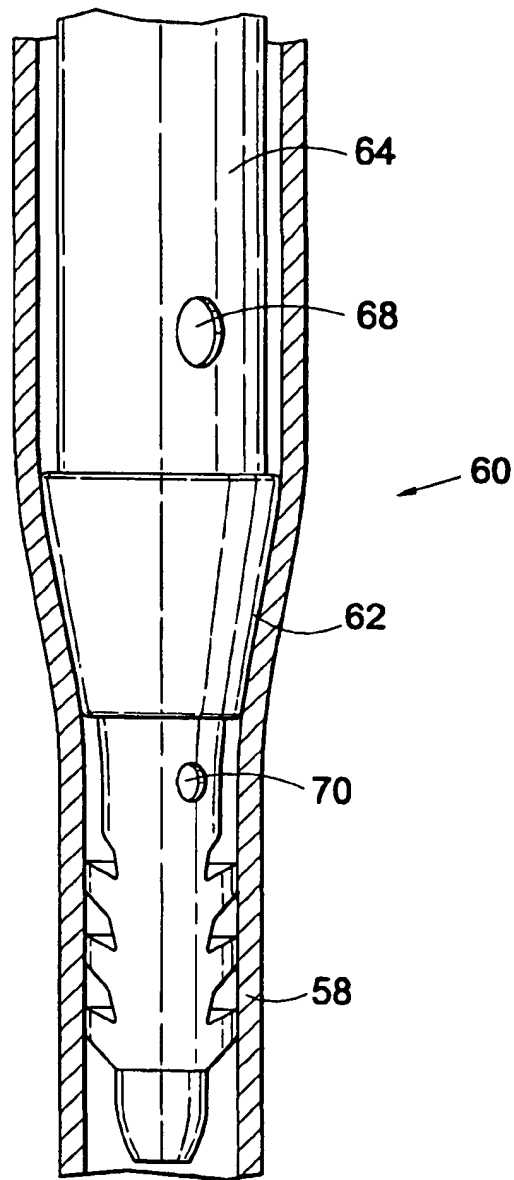

Fig.3

Fig.7



INTERNATIONAL SEARCH REPORT

International Application No
 PC 1, 03 01/04958

A. CLASSIFICATION OF SUBJECT MATTER
 IPC 7 E21B43/10 B21D26/02

According to International Patent Classification (IPC) or to both national classification and IPC

B. FIELDS SEARCHED

Minimum documentation searched (classification system followed by classification symbols)
 IPC 7 E21B B21D

Documentation searched other than minimum documentation to the extent that such documents are included in the fields searched

Electronic data base consulted during the international search (name of data base and, where practical, search terms used)

EPO-Internal, PAJ, WPI Data

C. DOCUMENTS CONSIDERED TO BE RELEVANT

Category *	Citation of document, with indication, where appropriate, of the relevant passages	Relevant to claim No.
X	DE 21 40 358 A (MO WYSSCHEE TEKHN UTSCHILISCHT;TSNII TECHNOLOGII MASH) 20 June 1973 (1973-06-20) page 5, paragraph 2 figure 1	16-18, 21,22, 24,25,38
A	WO 00 37766 A (ASTEC DEV LTD ;SIMPSON NEIL ANDREW ABERCROMBI (GB)) 29 June 2000 (2000-06-29) cited in the application the whole document	1,16-18, 23,24
A	GB 2 348 223 A (SHELL INT RESEARCH) 27 September 2000 (2000-09-27) cited in the application the whole document	1,16-18, 23,24
	-/--	

Further documents are listed in the continuation of box C.

Patent family members are listed in annex.

* Special categories of cited documents:

- *A* document defining the general state of the art which is not considered to be of particular relevance
- *E* earlier document but published on or after the international filing date
- *L* document which may throw doubts on priority claim(s) or which is cited to establish the publication date of another citation or other special reason (as specified)
- *O* document referring to an oral disclosure, use, exhibition or other means
- *P* document published prior to the international filing date but later than the priority date claimed

- *I* later document published after the international filing date or priority date and not in conflict with the application but cited to understand the principle or theory underlying the invention
- *X* document of particular relevance; the claimed invention cannot be considered novel or cannot be considered to involve an inventive step when the document is taken alone
- *Y* document of particular relevance; the claimed invention cannot be considered to involve an inventive step when the document is combined with one or more other such documents, such combination being obvious to a person skilled in the art.
- *8* document member of the same patent family

Date of the actual completion of the international search

22 January 2002

Date of mailing of the international search report

30/01/2002

Name and mailing address of the ISA

European Patent Office, P.B. 5818 Patentlaan 2
 NL - 2280 HV Rijswijk
 Tel. (+31-70) 340-2040, Tx. 31 651 epo nl,
 Fax: (+31-70) 340-3016

Authorized officer

Schouten, A

INTERNATIONAL SEARCH REPORT

International Application No
PCT/GB 01/04958

C.(Continuation) DOCUMENTS CONSIDERED TO BE RELEVANT		
Category *	Citation of document, with indication, where appropriate, of the relevant passages	Relevant to claim No.
A	GB 2 347 950 A (SHELL INT RESEARCH) 20 September 2000 (2000-09-20) cited in the application the whole document ---	1,16-18, 23,24
A	GB 2 344 606 A (SHELL INT RESEARCH) 14 June 2000 (2000-06-14) cited in the application the whole document -----	1,16-18, 23,24

INTERNATIONAL SEARCH REPORT

 International Application No
 PCT/GB 01/04958

Patent document cited in search report		Publication date	Patent family member(s)	Publication date
DE 2140358	A	20-06-1973	DE 2140358 A1	20-06-1973
WO 0037766	A	29-06-2000	AU 1867900 A	12-07-2000
			AU 1868700 A	12-07-2000
			AU 1868800 A	12-07-2000
			AU 1868900 A	12-07-2000
			AU 1876600 A	12-07-2000
			AU 1876800 A	12-07-2000
			EP 1147287 A2	24-10-2001
			EP 1141517 A1	10-10-2001
			EP 1141515 A1	10-10-2001
			EP 1144802 A2	17-10-2001
			EP 1151180 A1	07-11-2001
			EP 1141518 A1	10-10-2001
			WO 0037766 A2	29-06-2000
			WO 0037771 A1	29-06-2000
			WO 0037768 A1	29-06-2000
			WO 0037767 A2	29-06-2000
			WO 0037772 A1	29-06-2000
			WO 0037773 A1	29-06-2000
			GB 2345308 A	05-07-2000
			GB 2346632 A	16-08-2000
			GB 2346400 A	09-08-2000
			GB 2346909 A	23-08-2000
			GB 2347445 A	06-09-2000
			NO 20012596 A	27-07-2001
			NO 20012597 A	27-07-2001
			NO 20012598 A	30-07-2001
			NO 20012599 A	30-07-2001
			NO 20012600 A	30-07-2001
			NO 20012865 A	07-08-2001
GB 2348223	A	27-09-2000	NO 20001281 A	12-09-2000
GB 2347950	A	20-09-2000	AU 1349200 A	17-08-2000
			BR 0000327 A	10-10-2000
			DE 10005799 A1	02-11-2000
			NO 20000677 A	14-08-2000
GB 2344606	A	14-06-2000	AU 5933599 A	08-06-2000
			BR 9906143 A	05-09-2000
			DE 19958399 A1	13-07-2000
			NO 995991 A	08-06-2000
			US 6263966 B1	24-07-2001
			US 2001047870 A1	06-12-2001
			US 2001047866 A1	06-12-2001
			US 2001045289 A1	29-11-2001